

PVC-U ANGLE SEAT REGULATOR VALVE

VÁLVULA DE ASIENTO INCLINADO REGULADORA PVC-U



Sizes	Solvent socket: D20 (DN15) Threaded: ½" (DN15)	
Standards	Solvent socket - Metric Threaded - BSP	EN ISO 1452, EN ISO 15493 ISO 228-1
Working pressure	@ 20°C (73°F) D20 (½"): PN 16 (240 psi)	
Materials	O-rings: EPDM (FPM optional)	
Characteristics	<ul style="list-style-type: none"> • Flow rate regulator valve. • 100% factory tested. • A cone closing system on top of an EPDM O-Ring. • Connections: 3 pieces union, solvent female, solvent male and male threaded. • Minimal pressure drop. • Easy disassembling. • Shaft with a graduated to regulate valve position. 	<ul style="list-style-type: none"> • Válvula reguladora de caudal. • Testadas al 100% en fábrica. • Sistema de cierre por cono sobre junta en EPDM. • Conexiones 3 piezas, encolar hembra, encolar macho y roscar macho. • Baja pérdida de carga. • Fácil desmontaje. • Eje con escala graduada para regular mejor la posición.
Certifications		

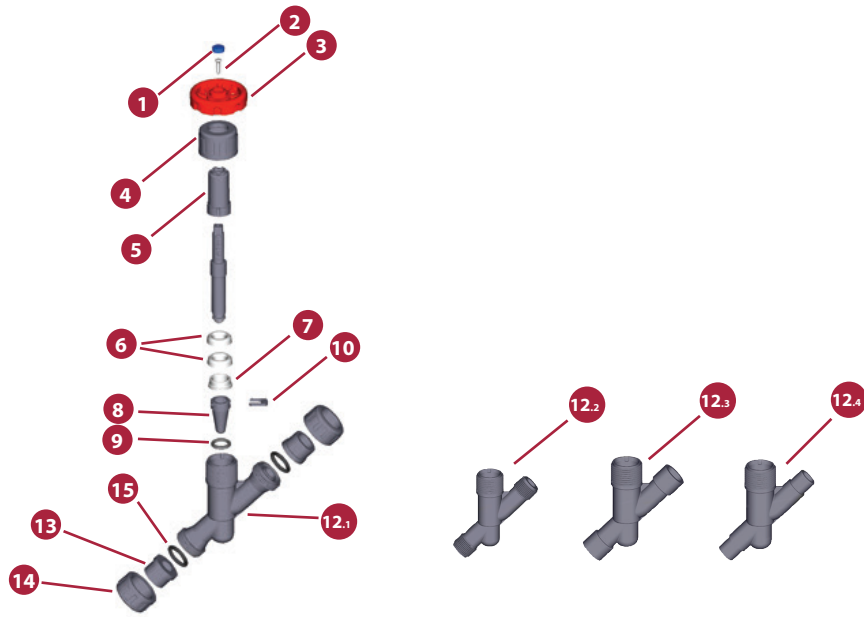
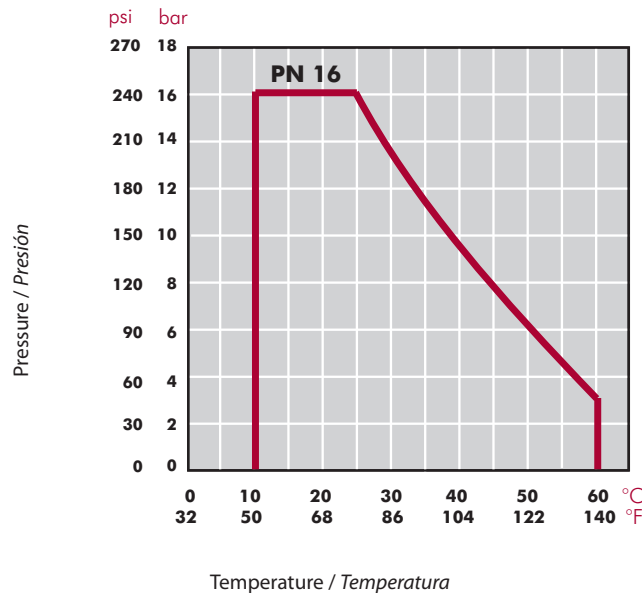

FIG.	Parts	Despiece	Material
1	Plug	Tapón	PP
2	Bolt	Tornillo	Stainless steel
3	Handwheel	Volante	ABS
4	Bonnetnut	Tuerca	PVC-U
5	Bonnet	Prensa retén	PVC-U
6	Sealing rings	Juntas retén	HDPE
7	Sealing stop	Tope retén	PVC-U
8	Conical seat	Asiento cónico	PVC-U
9	Sealing gasket	Junta cierre	HDPE
10	Safety pin	Pasador seguro	PVC-U
11	Stem	Eje	PVC-U
12	Body	Cuerpo	PVC-U
13	End connector	Manguito	PVC-U
14	Union nut	Tuerca	PVC-U
15	O-ring	Junta tórica	EPDM

PRESSURE / TEMPERATURE GRAPH
DIAGRAMA PRESIÓN / TEMPERATURA



Life: 25 years
Hydrostatic maximum pressure a component may withstand in continuous service (without overpressure)

Vida útil: 25 años
Presión hidrostática máxima que un componente es capaz de soportar en servicio continuo (sin sobrepresión)

PRESSURE LOSS DIAGRAM
DIAGRAMA DE PÉRDIDAS DE CARGA

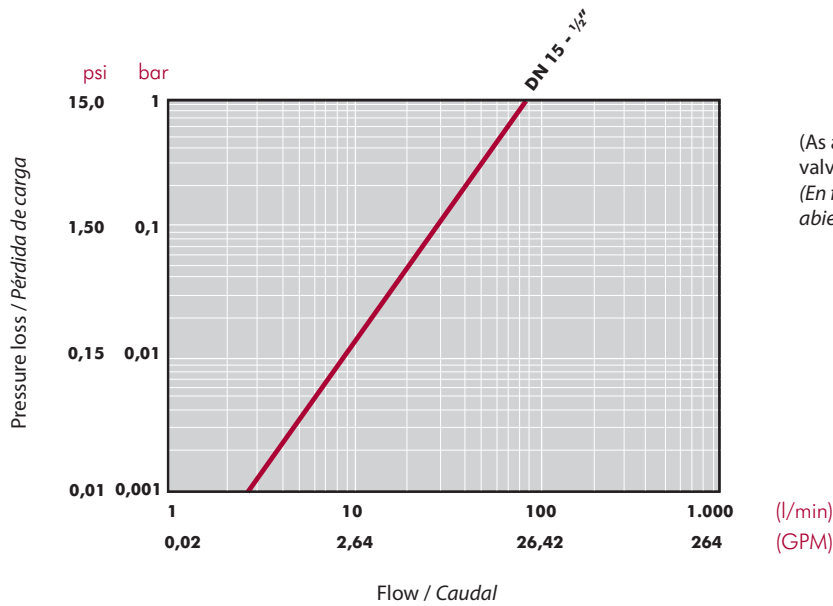

(As a function of flow reate w/open valve)
(En función del caudal c/válvula abierta)

RELATIVE FLOW
FLUJO RELATIVO

D	20
DN	15
Kv100	90
Cv	6,3

$Cv = Kv_{100} / 14,28$
 Kv_{100} (l/min, $\Delta p = 1$ bar)
 Cv (GPM, $\Delta p = 1$ psi)

PERFORMANCE CHART
GRÁFICA DE RENDIMIENTO

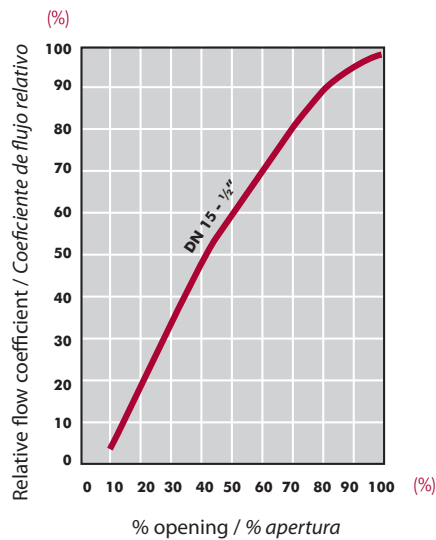

End connections

Always position the valve with the arrow pointing in the direction of flow.
There are several options for valve mounting on the line:
(12.1) Three-piece
(12.2) Male threaded
(12.3) Female solvent socket
(12.4) Male solvent socket

Conexiones al sistema

Orientar la válvula teniendo en cuenta la flecha que indica el sentido del flujo.
La válvula ofrece varios sistemas de montaje a la línea:
(12.1) Por medio de unión tres piezas
(12.2) Unión rosca macho
(12.3) Unión para encolar hembra
(12.4) Unión para encolar macho

UP. 75. SF - ANGLE SEAT REGULATOR VALVE

Angle seat regulator valve

- PVC-U body
- Female solvent socket
- Metric series
- O-Rings in EPDM

Válvula de asiento inclinado reguladora

- Cuerpo en PVC-U
- Encolar hembra
- Serie métrica
- Juntas en EPDM

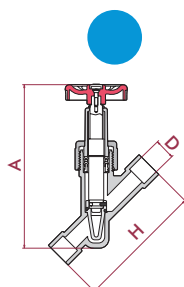
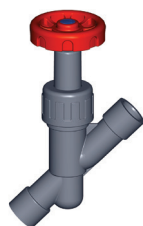

D	DN	PN	REF.	CODE
20	15	16	05 75 020	22884

H	A
124	158

UP. 75. 3SF - ANGLE SEAT REGULATOR VALVE

Angle seat regulator valve

- PVC-U body
- 3 pieces union
- Female solvent socket
- Metric series
- O-Rings in EPDM

Válvula de asiento inclinado reguladora

- Cuerpo en PVC-U
- Enlace 3 piezas
- Encolar hembra
- Serie métrica
- Juntas en EPDM

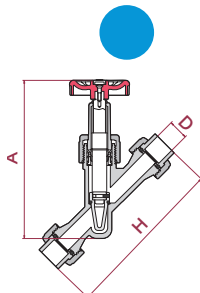
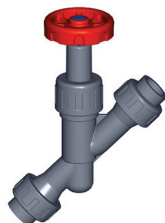

D	DN	PN	REF.	CODE
20	15	16	05 75 120	22885

H	A
164	158

UP. 75. SM - ANGLE SEAT REGULATOR VALVE

Angle seat regulator valve

- PVC-U body
- Male solvent socket
- Metric series
- O-Rings in EPDM

Válvula de asiento inclinado reguladora

- Cuerpo en PVC-U
- Encolar macho
- Serie métrica
- Juntas en EPDM

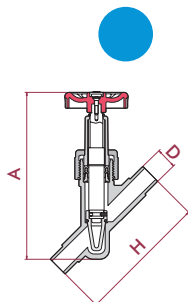
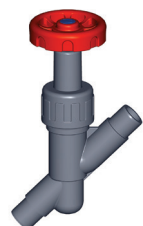

D	DN	PN	REF.	CODE
20	15	16	05 75 220	22886

H	A
124	158

UP. 75. MT - ANGLE SEAT REGULATOR VALVE

Angle seat regulator valve

- PVC-U body
- BSP male thread
- O-Rings in EPDM

Válvula de asiento inclinado reguladora

- Cuerpo en PVC-U
- Roscar macho BSP
- Juntas en EPDM

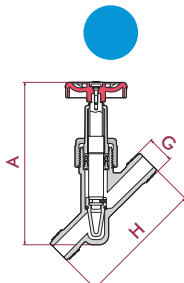
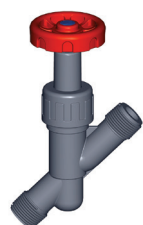

G	DN	PN	REF.	CODE
3/4"	15	16	05 75 425	22887

H	A
124	158

PVC-U ANGLE SEAT CHECK VALVE

VÁLVULA ASIENTO INCLINADO ANTIRETORNO PVC-U



Sizes	Solvent socket: D20 (DN15) Threaded: 1/2" (DN15)	
Standards	Solvent socket - Metric Threaded - BSP	EN ISO 1452, EN ISO 15493 ISO 228-1
Working pressure	@ 20°C (73°F) D20 (1/2"): PN 16 (240 psi)	
Materials	O-rings: EPDM (FPM optional)	
Characteristics	<ul style="list-style-type: none"> • Check valve. • For using vertically. • 100% factory tested. • The valve has an internal counterweight that works by gravity. • Minimal pressure drop. • Easy disassembling. • Connections: 3 pieces union, solvent female, solvent male and male threaded. 	<ul style="list-style-type: none"> • Válvula anti-retorno. • Funcionamiento en posición vertical. • Testadas al 100% en fábrica. • La válvula lleva incorporado un contrapeso interno que funciona por gravedad. • Baja pérdida de carga. • Desmontaje fácil. • Sistema de conexionado 3 piezas, encolar hembra, encolar macho y rosca macho.
Certifications		

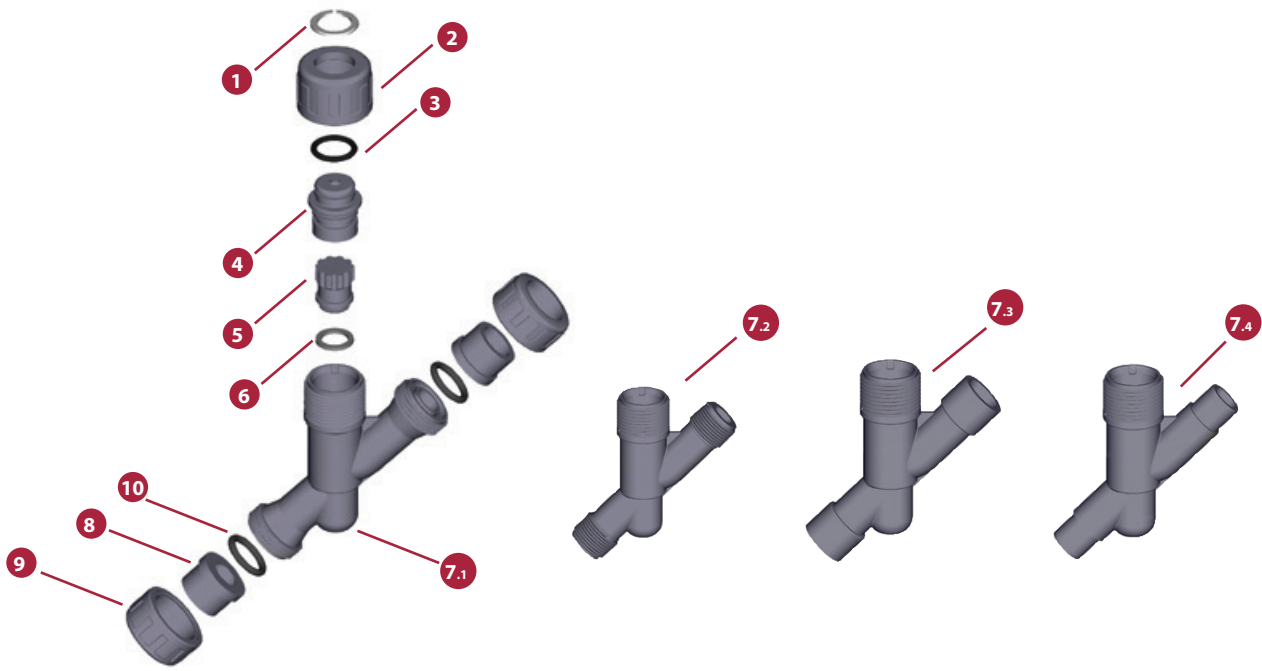
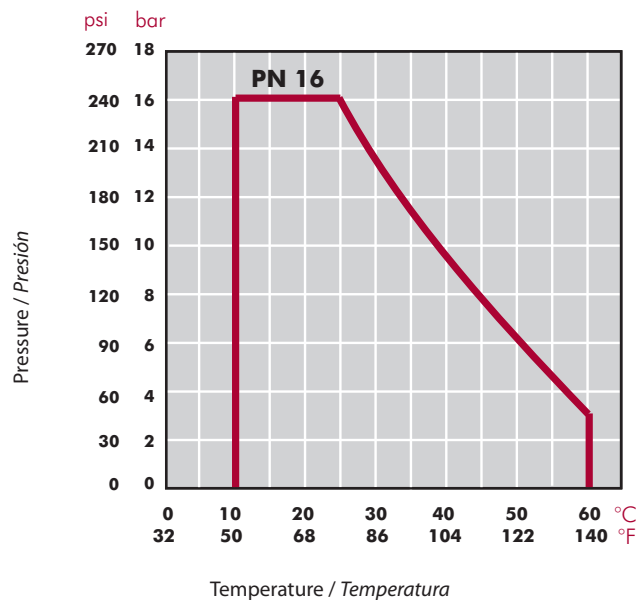

FIG.	Parts	Despiece	Material
1	Safety ring	Anillo seguro	PVC-U
2	Nut	Tuerca	PVC-U
3	O-ring	Junta tórica	EPDM / FPM
4	Plug	Tapón	PVC-U
5	Disc bonnet	Eje entretorno	PVC-U
6	Disc	Junta plana	EPDM / FPM
7	Body	Cuerpo	PVC-U
8	End connector	Manguito	PVC-U
9	Nut	Tuerca	PVC-U
10	O-ring	Junta tórica	EPDM

PRESSURE / TEMPERATURE GRAPH
DIAGRAMA PRESIÓN / TEMPERATURA



Life: 25 years
 Hydrostatic maximum pressure a component may withstand in continuous service (without overpressure)

Vida útil: 25 años
 Presión hidrostática máxima que un componente es capaz de soportar en servicio continuo (sin sobrepresión)

PRESSURE LOSS DIAGRAM
DIAGRAMA DE PÉRDIDAS DE CARGA

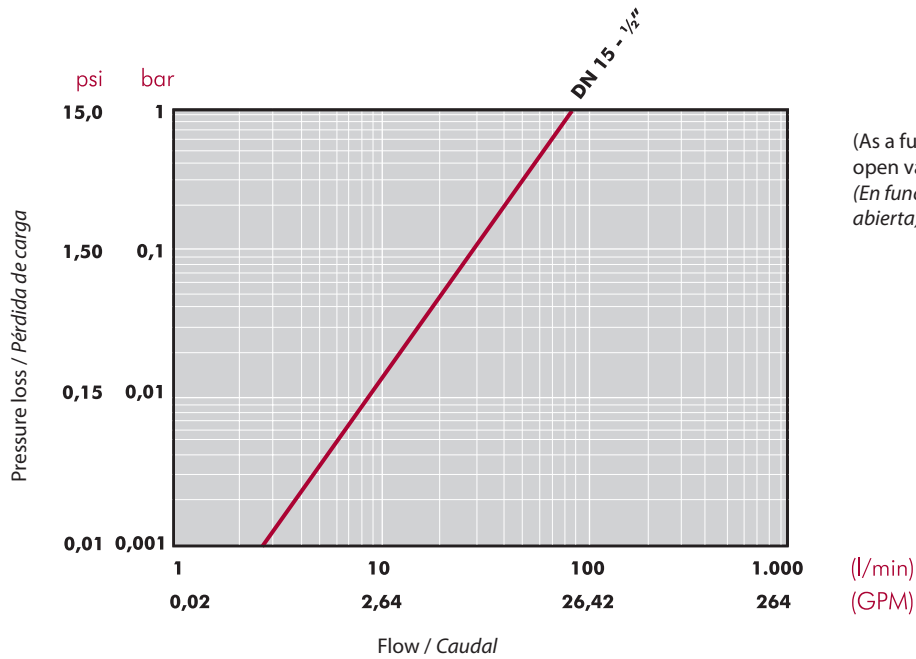

(As a function of flow reate w/
open valve)
(En función del caudal c/válvula
abierta)

RELATIVE FLOW
FLUJO RELATIVO

D	20
DN	15
Kv100	90
Cv	6,3

$Cv = Kv_{100} / 14,28$
 Kv_{100} (l/min, $\Delta p = 1$ bar)
 Cv (GPM, $\Delta p = 1$ psi)

End connections

Always position the valve with the arrow pointing in the direction of flow.

There are several options for valve mounting on the line:

- (7.1) Three-piece
- (7.2) Male threaded
- (7.3) Female solvent socket
- (7.4) Male solvent socket

Conexiones al sistema

Orientar la válvula teniendo en cuenta la flecha que indica el sentido del flujo.

La válvula ofrece varios sistemas de montaje a la línea:

- (7.1) Por medio de unión tres piezas
- (7.2) Unión rosca macho
- (7.3) Unión para encolar hembra
- (7.4) Unión para encolar macho

UP. 77. SF - ANGLE SEAT CHECK VALVE

Angle seat check valve

- PVC-U body
- Female solvent socket
- Metric series
- O-Rings in EPDM

Válvula de asiento inclinado anti-retorno

- Cuerpo en PVC-U
- Encolar hembra
- Serie métrica
- Juntas en EPDM

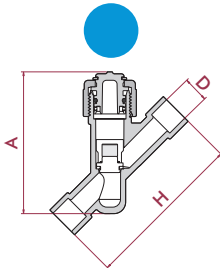
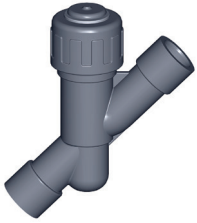

D	DN	PN	REF.	CODE
20	15	16	05 77 020	22889

H	A
124	109

UP. 77. 3SF - ANGLE SEAT CHECK VALVE

Angle seat check valve

- PVC-U body
- 3 pieces union
- Female solvent socket
- Metric series
- O-Rings in EPDM

Válvula de asiento inclinado anti-retorno

- Cuerpo en PVC-U
- Enlace 3 piezas
- Encolar hembra
- Serie métrica
- Juntas en EPDM

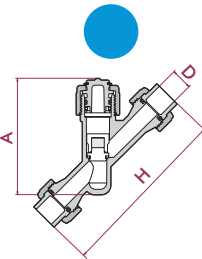

D	DN	PN	REF.	CODE
20	15	16	05 77 120	22890

H	A
164	109

UP. 77. SM - ANGLE SEAT CHECK VALVE

Angle seat check valve

- PVC-U body
- Male solvent socket
- Metric series
- O-Rings in EPDM

Válvula de asiento inclinado anti-retorno

- Cuerpo en PVC-U
- Encolar macho
- Serie métrica
- Juntas en EPDM

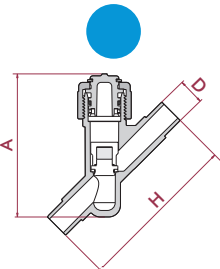
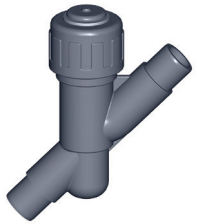

D	DN	PN	REF.	CODE
20	15	16	05 77 220	22891

H	A
124	109

UP. 77. MT - ANGLE SEAT CHECK VALVE

Angle seat check valve

- PVC-U body
- BSP male thread
- O-Rings in EPDM

Válvula de asiento inclinado anti-retorno

- Cuerpo en PVC-U
- Roscar macho BSP
- Juntas en EPDM

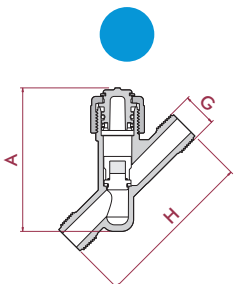
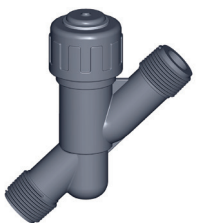

G	DN	PN	REF.	CODE
3/4"	15	16	05 77 425	22892

H	A
124	109

PVC-U LINE STRAINER
FILTRO EN LÍNEA PVC-U



Sizes	Solvent socket: D20 (DN15) Threaded: ½" (DN15)	
Standards	Solvent socket - Metric Threaded - BSP	EN ISO 1452, EN ISO 15493 ISO 228-1
Working pressure	@ 20°C (73°F) D20 (½"): PN 16 (240 psi)	
Materials	O-rings: EPDM (FPM optional)	
Characteristics	<ul style="list-style-type: none"> • Line strainer. • 4 mm² mesh. • It is used to retain little stones or particles that can get into the circuit. • 100% factory tested. • Minimal pressure drop. • Easy disassembling. • Connections: 3 pieces union, solvent female, solvent male and male threaded. • The filter has to be assembled so that the body faces downwards. This makes cleaning easier through the down cap. 	<ul style="list-style-type: none"> • Filtro. • Tamiz de 4 mm². • Se utiliza para retener pequeñas piedras u objetos que puedan entrar en el circuito. • Testadas al 100% en fábrica. • Baja pérdida de carga. • Desmontaje fácil. • Sistema de conexionado 3 piezas, encolar hembra, encolar macho y rosca macho. • El filtro debe montarse de manera que el cuerpo quede hacia abajo. De esta forma se facilita su limpiado por medio del tapón inferior.
Certifications		

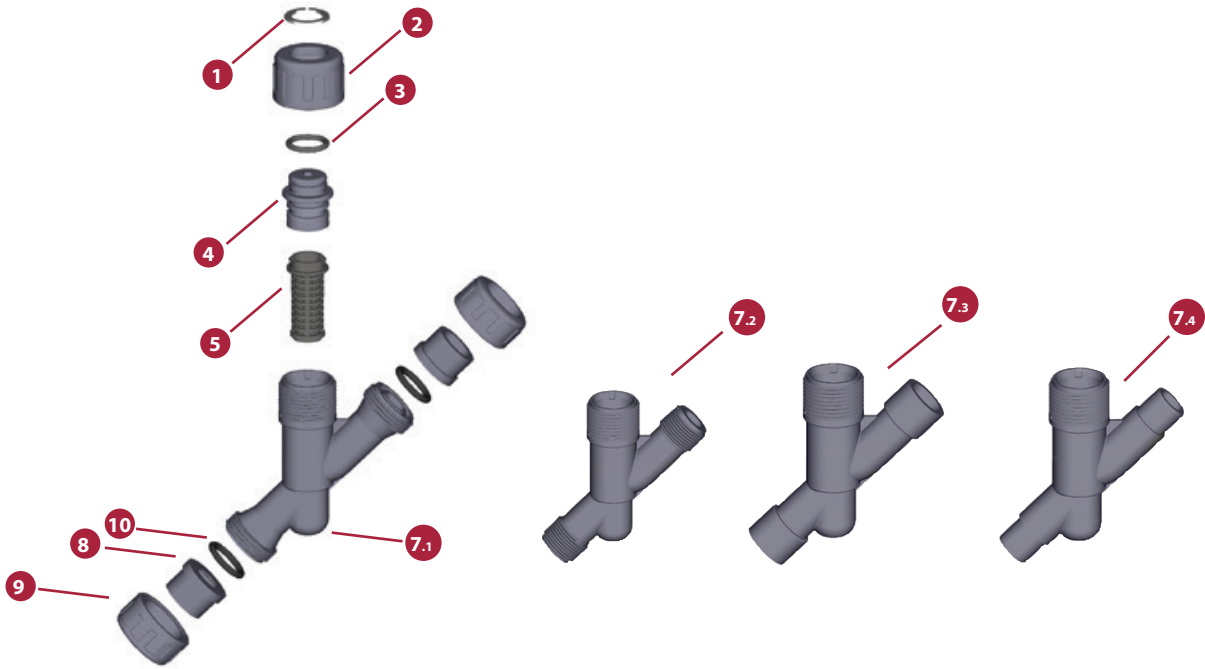
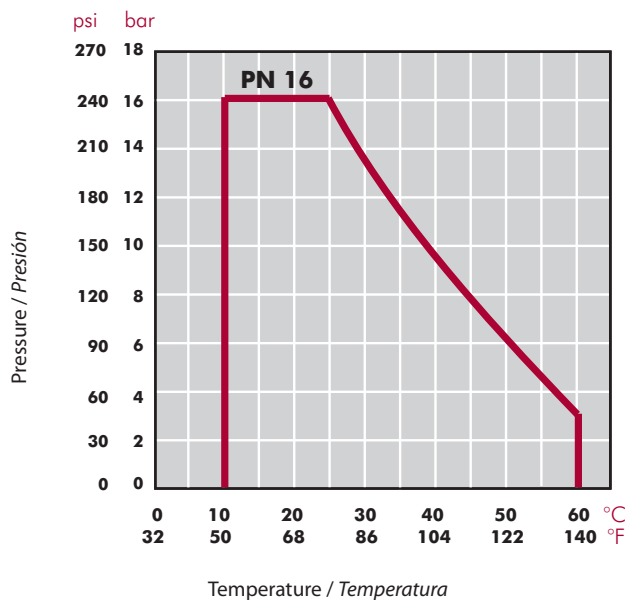

FIG.	Parts	Despiece	Material
1	Safety ring	Anillo seguro	PVC-U
2	Nut	Tuerca	PVC-U
3	O-ring	Junta tórica	EPDM / FPM
4	Plug	Tapón	PVC-U
5	Screen	Rejilla	PP
7	Body	Cuerpo	PVC-U
8	End connector	Manguito	PVC-U
9	Nut	Tuerca	PVC-U
10	O-ring	Junta tórica	EPDM / FPM

PRESSURE / TEMPERATURE GRAPH
DIAGRAMA PRESIÓN / TEMPERATURA



Life: 25 years
 Hydrostatic maximum pressure a component may withstand in continuous service (without overpressure)

Vida útil: 25 años
 Presión hidrostática máxima que un componente es capaz de soportar en servicio continuo (sin sobrepresión)

PRESSURE LOSS DIAGRAM
DIAGRAMA DE PÉRDIDAS DE CARGA

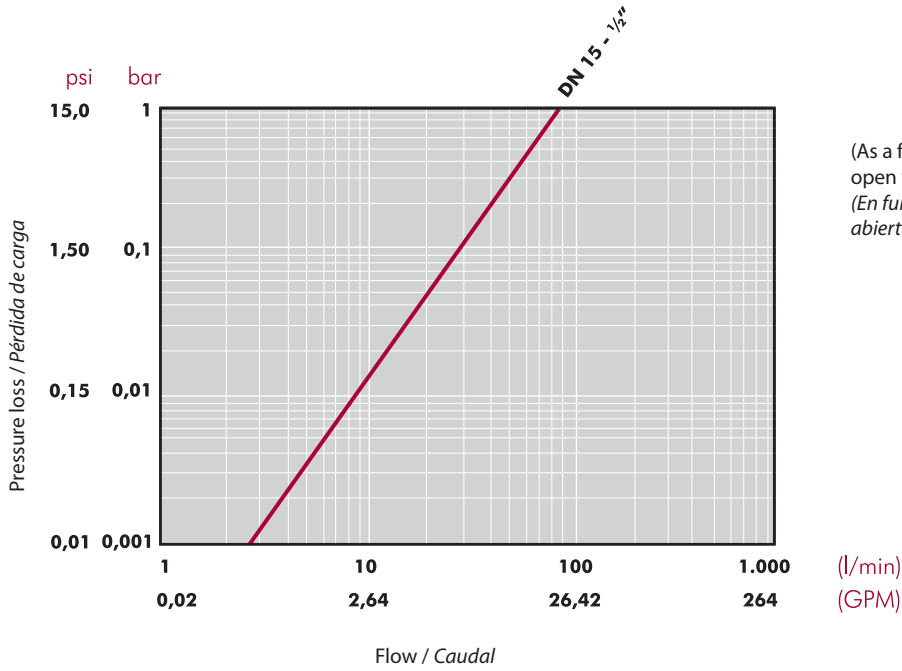

(As a function of flow reate w/
open valve)
(En función del caudal c/válvula
abierta)

RELATIVE FLOW
FLUJO RELATIVO

D	20
DN	15
Kv100	90
Cv	6,3

$Cv = Kv_{100} / 14,28$
 Kv_{100} (l/min, $\Delta p = 1$ bar)
 Cv (GPM, $\Delta p = 1$ psi)

End connections

Always position the valve with the arrow pointing in the direction of flow. The line strainer body must be pointing downward.

There are several options for line strainer mounting:

- (7.1) Three-piece
- (7.2) Male screwed
- (7.3) Female socket weld
- (7.4) Male socket weld

No dismounting is required for maintenance of the line strainer once it is installed.

Conexiones al sistema

Orientar el filtro teniendo en cuenta la flecha que indica el sentido del flujo. El cuerpo del filtro debe quedar hacia abajo.

El filtro ofrece varios sistemas de montaje a la línea:

- (7.1) Por medio de unión tres piezas
- (7.2) Unión rosca macho
- (7.3) Unión para encolar hembra
- (7.4) Unión para encolar macho

El filtro permite efectuar el mantenimiento sin tener que desmontar el cuerpo.

UP. 76. SF - LINE STRAINER

Line strainer

- PVC-U body
- Female solvent socket
- Metric series
- O-Rings in EPDM

Filtro en línea

- Cuerpo en PVC-U
- Encolar hembra
- Serie métrica
- Juntas en EPDM

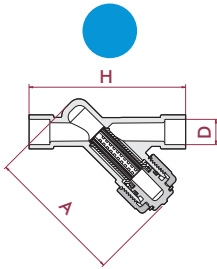
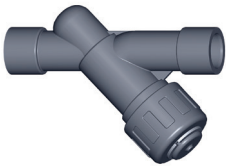

D	DN	PN	REF.	CODE
20	15	16	05 76 020	25713

H	A
124	109

UP. 76. 3SF - LINE STRAINER

Line strainer

- PVC-U body
- 3 pieces union
- Female solvent socket
- Metric series
- O-Rings in EPDM

Filtro en línea

- Cuerpo en PVC-U
- Enlace 3 piezas
- Encolar hembra
- Serie métrica
- Juntas asiento en EPDM

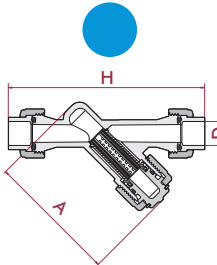
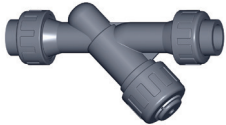

D	DN	PN	REF.	CODE
20	15	16	05 76 120	25714

H	A
164	109

UP. 76. SM - LINE STRAINER

Line strainer

- PVC-U body
- Male solvent socket
- Metric series
- O-Rings in EPDM

Filtro en línea

- Cuerpo en PVC-U
- Encolar macho
- Serie métrica
- Juntas en EPDM

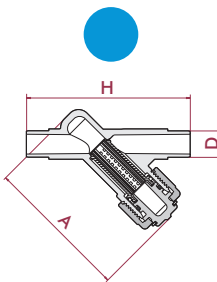
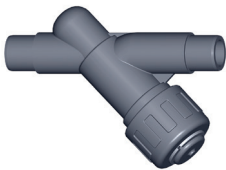

D	DN	PN	REF.	CODE
20	15	16	05 76 220	25715

H	A
124	109

UP. 76. MT - LINE STRAINER

Line strainer

- PVC-U body
- BSP male thread
- O-rings in EPDM

Filtro en línea

- Cuerpo en PVC-U
- Roscar macho BSP
- Juntas en EPDM

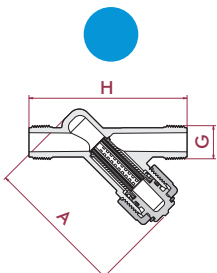

G	DN	PN	REF.	CODE
3/4"	15	16	05 76 425	25716

H	A
124	109